

31st August, 2021

To,
NSE Limited,
Exchange Plaza,
Plot No. C/1, G-Block,
Bandra-Kurla Complex,
Bandra (E), Mumbai 400 051

Symbol: SINTERCOM
Series: EQ

Sub: Investor Presentation

Dear Sir/ Madam,

Please find enclosed herewith updated Investor Presentation.

Please take the note of the same.

**For and on behalf of
Sintercom India Limited**



**Anuja Joshi
Company Secretary & Compliance Officer**



SINTERCOM
India Ltd.

INVESTOR PRESENTATION
August 2021



Company Overview



Company Overview



- Established in 2007, Sintercom India Limited is the leading automotive sintered components manufacturer located in Pune, India.
- The Company has integrated manufacturing facilities and has increased its capacity from 1,980 MTPA to 3,600 MTPA in 2019.
- The Company specializes in manufacturing medium to high-density sintered components for automotive engines, powertrain, and exhaust systems and also manufactures sensor components that cater to global markets.
- The product portfolio includes drivetrain gears, engine sprockets, pulleys, crankshaft bearing journals, transmission gears, and synchro hubs, as well as ABS rings and Sensor Hego bosses and flanges.
- Sintercom provides its esteemed customers with high-volume, high-precision, and low-cost components, tailored to their specific requirements. This is ensured by leveraging the integrated manufacturing facility adhering to rigorous quality standards.
- The company entered into a strategic tie-up with Miba Sinter with a Joint Venture and technology transfer agreement in 2011, and Miba also invested in Sintercom to become a co-promoter by taking around 26% stake in the company.
- Together with the technology leader Miba, the company is able to provide their customers with even more competitive solutions with powder metal.
- Sintercom caters to OEMs like Maruti Suzuki Limited, Mahindra & Mahindra Limited, Bajaj Auto Limited, and Fiat India Automobiles Private Limited and the company is a single-source supplier for various products as well.
- An in-house dedicated Research & Development team develops new products used in various applications of engine, transmission, and body chassis for various automotive OEMs and Tier-1 customers.

Revenue (INR Mn) & EBITDA Margin (%)

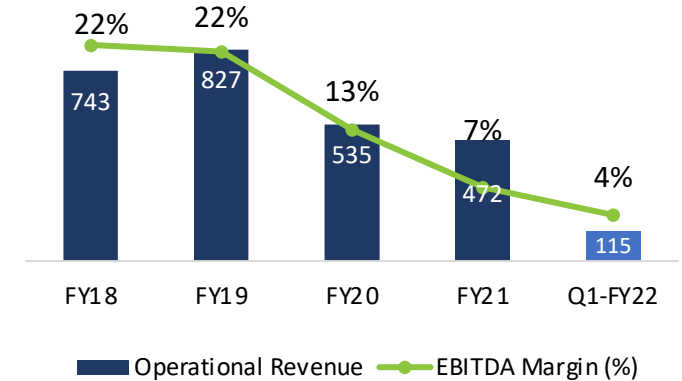

Q1-FY22 Region Wise Revenue Breakup



- The Miba Sinter Group established in 1963, has decades of experience in the Sinter Technology and is one of the leader in the Global Sintering Industry.
- Miba Sinter Austria GmbH manufactures high precision and sintered components. The Company offers engine bearings, friction materials, power electronics components, and coatings for engines, gearboxes, shock absorbers, specific applications, and compressors.
- They work closely with their customers to meet the challenges of the international automotive industry related to making vehicles more efficient, environmentally friendly, and quieter.
- Backed up by a global presence, years of development experience, and quality standards, Miba’s customers are guaranteed customized and cost-effective solutions.
- Through ongoing technological progress, the Miba Sinter Group creates high-end components for the vehicles of tomorrow.
- Miba sintered components offer an efficient and cost-effective technology for mass production, are environmentally friendly due to the high level of recycled content and optimum utilization of materials make engines and transmissions significantly quieter than steel or castings.
- Miba Sinter Group expands its global network with strategic tie-up with Sintercom India Ltd.
- The Joint Venture and technology agreement with Sintercom provides access to various advanced sintered technology solutions for the various Indian OEMs.
- With the growing opportunities in the Indian market, Miba Sinter Austria further invested in Sintercom India Ltd. for an aggregate amount of approximately INR 222 Mn.
- Sintercom completed the raising of funds from Miba Sinter on a preferential private placement basis in the form of equity shares and compulsory convertible debentures (CCDs).

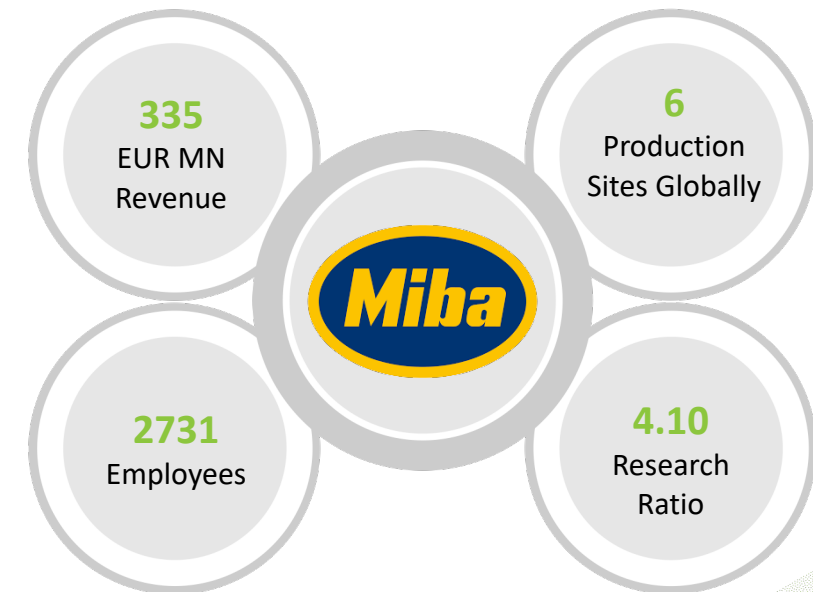
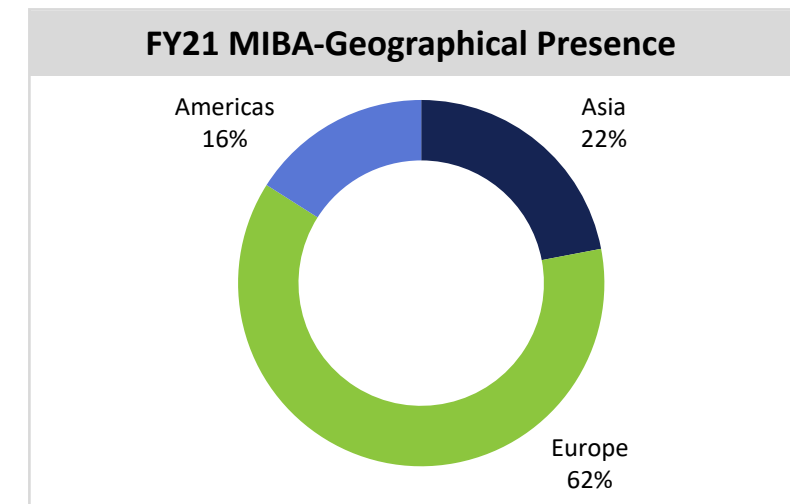

Milestones

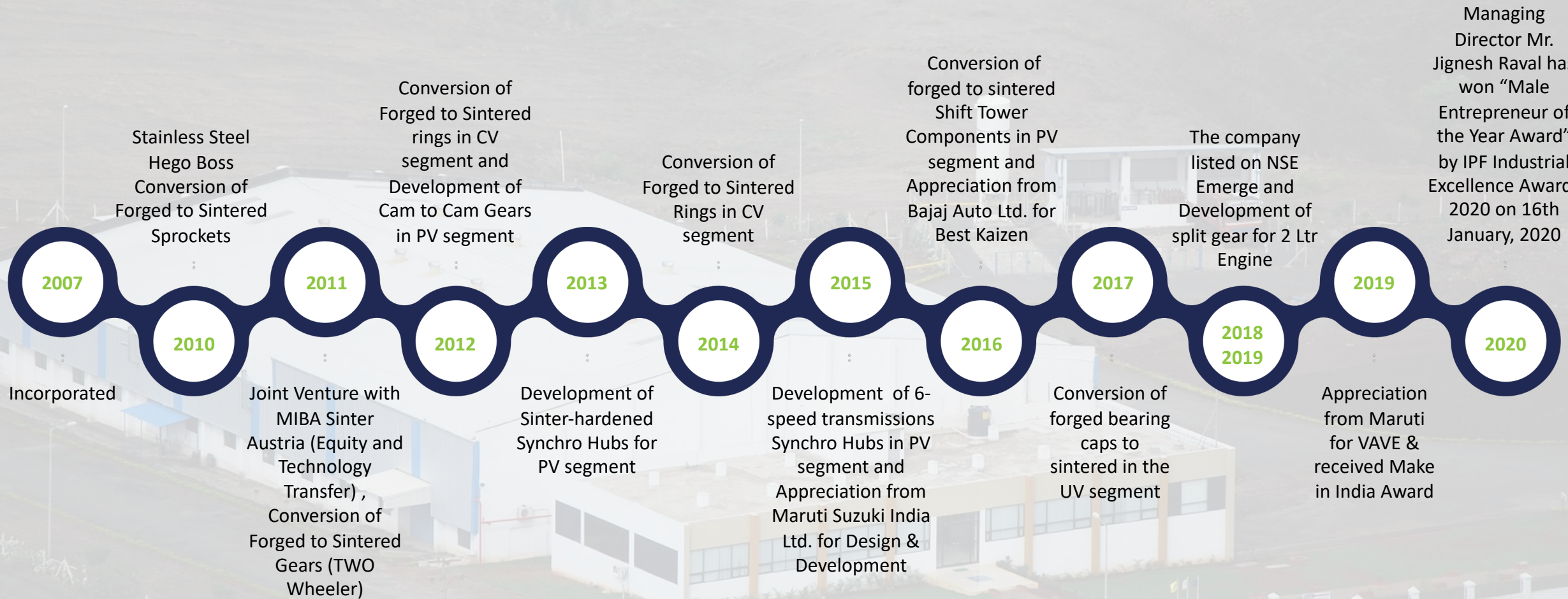

SINTERCOM – PIONEER IN SINTERING TECHNOLOGY IN INDIA

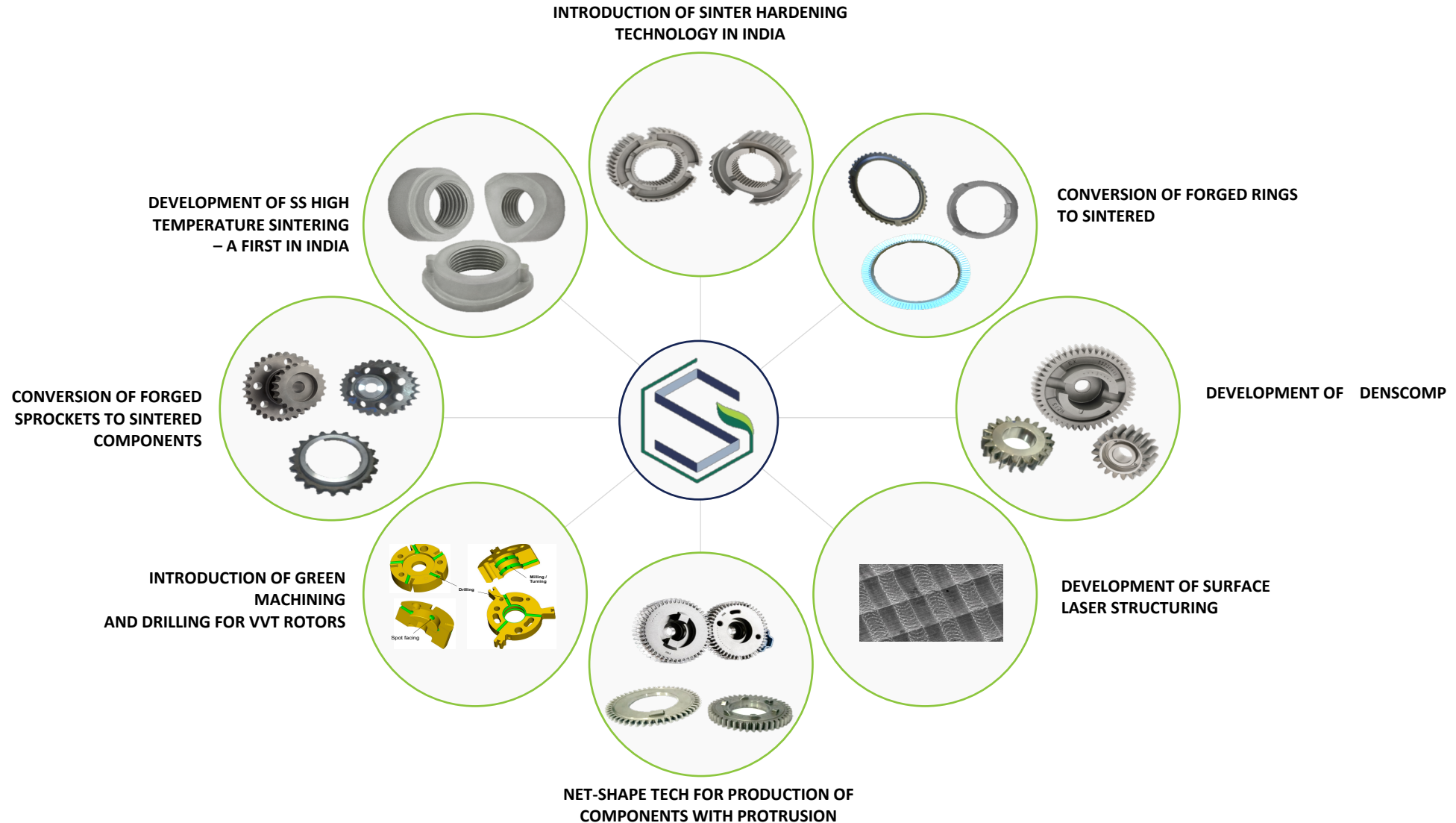

Our Vision and Mission

- Global leadership in sintering business by providing innovative technology for processes & people
- Increase sinter component leverage in an automobile up to 10 kgs. per vehicle
- Innovation in Motion –Technologies for a Cleaner Planet
- Improve awareness about the sintering technology in Indian manufacturing industries
- Improve the material yield using sintering technology

Our Values

- Technology Leadership
- Lifelong Learning
- Entrepreneurship
- Passion for Success

Our Strength

- Proven capability in producing medium to high density sintered parts
- Fully integrated manufacturing facility
- Adhering to superior quality standards
- Focus on automotive components and drivetrain parts
- In-house R&D and tool development
- Broad portfolio of sintered components and materials, including stainless steel parts

Hari Nair, Chairman

- Member of Board active since 2015
- 25+ years of experience at Tenneco, COO at Tenneco for 5 years, CEO at Anitar Investments, M&A Consultant at NM Rothschild & Sons, Member of Board of Directors & Chairman of Compensation Committee at Owens-Illinois since 2013, Member of Board of Directors at Delphi Technologies PLC and Musashi Seimitsu Industry.
- Degrees from Harvard Business School, the University of Notre Dame, and Bradley University



Jignesh Raval, Managing Director

- Member of Board & Managing Director active since 2007
- 9 years of experience at Tenneco Inc as Executive Director, GSCM 20+ years of experience in the automotive industry
- Degree in Engineering

Madan Godse, Independent Director

- Member of the board of our company since November 2017 as an independent director.
- He was associated with Cummins India Limited and its subsidiary Cummins Diesel Sales and Service (India) Limited from November 1984 to September 2005 as Company Secretary, Head of Legal Department, and subsequently as Vice President – Legal and Company Secretary.
- He is a member of the Bar Council of Maharashtra & Goa and has over 30 years of work experience in secretarial compliance and law
- He is a practicing advocate and regularly appears before National Company Law Tribunal, Mumbai.
- Degrees from Tilak Maharashtra University, Institute of Company Secretaries of India



Dara Kalyaniwala, Independent Director

- Joined as an Independent Director
- He has worked as Deputy General Manager Corporate Finance & Taxation with Grindwell Norton Limited, Mumbai for a decade
- 27 years' experience in Equity Capital Market, consulted various companies in formulating Business Strategies and managed M&A's, Buybacks, Takeovers & Delisting. He worked as Head- Investment Banking with PL Capital Markets Private Limited (Prabhudas Lilladher Group), Mumbai- as an employee from January 2008 to April 2016 and as a contracted professional from April 2016 till date.
- He is also a visiting faculty at the Institute of Chartered Accountants of India, The Institute of Company Secretaries of India; ICFAI Institute, National Institute of Capital Markets, Indo-German Training Institute, and some Trade Organizations.

Madhavi Pandrangi, Independent Director

- Recently joined the Board, Madhavi is currently practicing professional advising clients on various fields.
- She has over 20 years of experience specializing in valuation and business advisory
- She worked at Deloitte specializing in valuations and deals and was a Director in the valuation team at PwC for around 15 years
- A Chartered Accountant and also Certified Public Accountancy from State of Colorado & Certified Information Systems Audit



Bernd Badurek, Board of Director

- Newly appointed member of the board as of 27th May 2021
- He is the Member of the Executive Committee Miba AG and Managing Director & Chief Sales Officer of Miba Sinter Group. He has more than 20 years of international experience in sales & marketing
- He holds a university degree in business administration.

Pankaj Bhatawadekar, Chief Financial Officer

- Joined Sintercom Team in 2009
- Certified Chartered Accountant from ICAI.
- Experience in Finance field more than 15 years
- Responsible for Finance, HR & IR, Store & Dispatch, and IT



Nikhil Chavan, Sr. General Manager

- Joined Sintercom Team in 2007
- Degree from University of Pune.
- More than 14 years experience in the field of Automotive Industry
- Responsible for Process Excellence & Q.A, In House Tool Room, Strategic Sourcing, Supplier Development Operation (Compaction, Sizing, Sintering, Machine Shop , PPC & LSCM), Maintenance / Sales, and Logistics

Sameer Gupta, Sr. General Manager

- Joined Sintercom Team in 2019
- PGDM from University of Delhi.
- More than 20 years experience in the field of Automotive
- Responsible for Industry, Project / Solution, and Marketing



Swapnil Phand, Deputy General Manager

- Joined Sintercom Team in 2008
- Diploma from MSEBTE.
- More than 12 years experience in the field of Automotive Industry
- Responsible for Research Development & Engineering Team

Awards & Recognitions



Mr. Jignesh Raval has won “Male Entrepreneur of the Year Award” by IPF Industrial Excellence Awards 2020



Business Excellence Award for “Best Supplier - Make in India” awarded by Dun & Bradstreet during the year 2019-20.



Appreciation from Maruti Suzuki for VAVE



Appreciation from Bajaj Auto Ltd. for Best Kaizen



Appreciation from Maruti Suzuki for Design & Development

What is Sintering and Advantages



- Sintering is a heat treatment commonly used to increase the strength and structural integrity of a given material. The temperature used for sintering is below the melting point of the major constituent of the Powder Metallurgy material. After compaction, the neighboring powder particles are held together by cold welds, which give the compact sufficient “green strength” to be handled. At sintering temperature, diffusion processes cause necks to form and grow at these contact points by which a powder compact is transformed to a strong, dense ceramic body upon heating.
- It is different from the traditional metal forming processes wherein a solid mass of raw material is shaped into a final shape using chipping, pressing, heating and melting.
- At the start of the sintering process, highly complex tools are used to compress metal powder mixes.
- Compared with other production processes, sinter technology allows maximum material utilization with the lowest possible energy use.
- Whether in engines, transmissions, steering systems or for electrification – the properties of sintered components make them ideal for high-quality mechanical components and for systems.
- The porous spaces between the material's particles are minimized during the sintering process as the material is squeezed together under high temperature and pressure

KEY ADVANTAGES:

- Allows making complex products
- Cost savings
- High strength and precision
- Cost economy compared with other processes
- Products ready for assembly

	Sintering	Casting
Definition	Sintering is the process of compacting and forming a solid mass of material by heat and/or pressure without melting it to the point of liquefaction	The manufacturing process in which a liquid material is usually poured into a mold, which contains a hollow cavity of the desired shape, and then allowed to solidify
Quality	Consistent high quality	Inconsistent high quality
Material Implications	Greater flexibility in material usage	Non Ferrous metals, so low melting point
Mechanical Properties	High variability	Limited variability
Cost	Less waste/machining leading to lower cost on average	More waste/machining so higher cost on average

Manufacturing Process

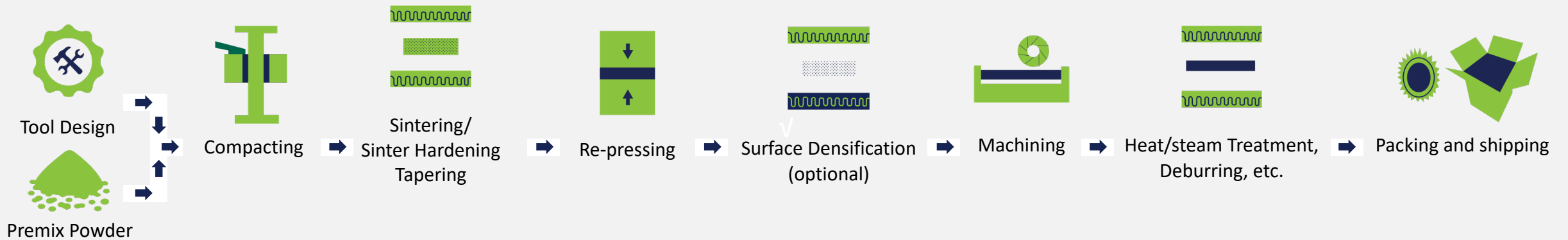

Responsible Use of Resources



General Production Process Flow



Every Process stage has been linked with SAP for traceability and monitoring

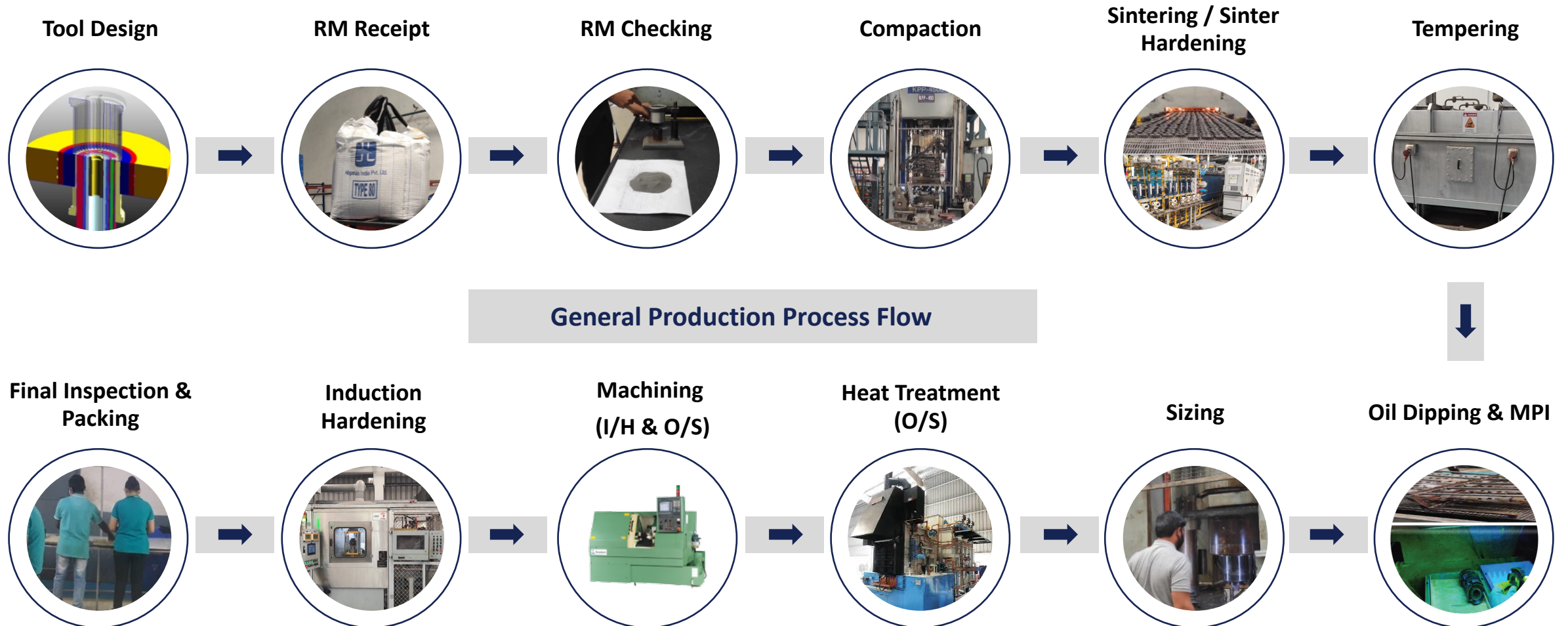



Tool Design

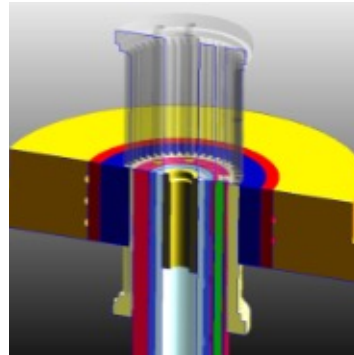

RM Checking

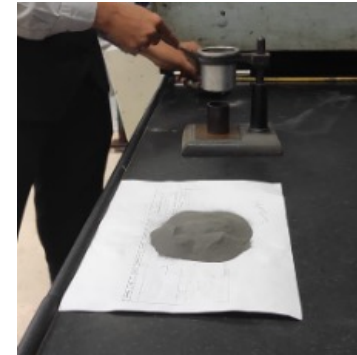

Compaction



Sintering / Sinter Hardening



Final Inspection & Packing



Machining (I/H & O/S)



OEM Clients



BHARATBENZ



TIER - 1

SCHAEFFLER



Client-wise Revenue (Q1-FY22)

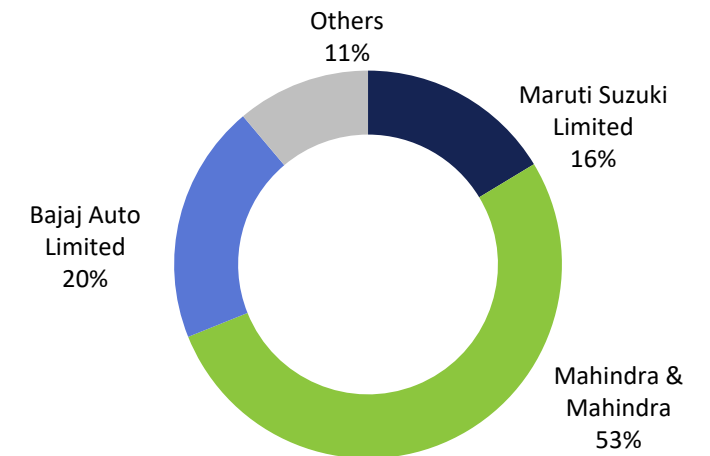

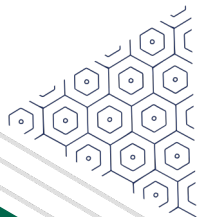

Business Overview



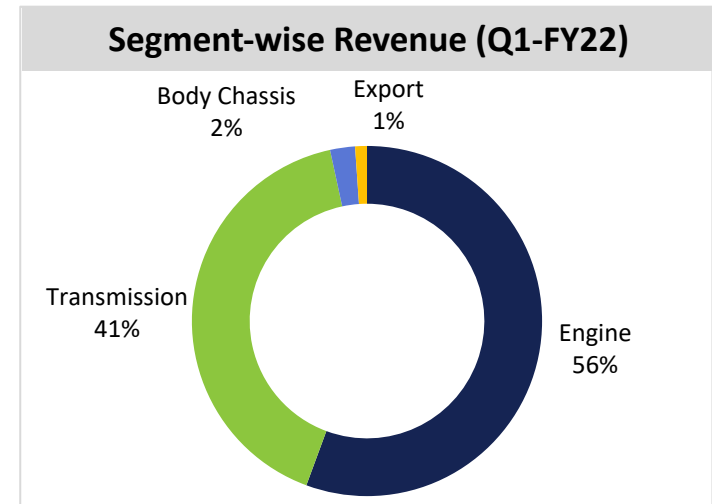
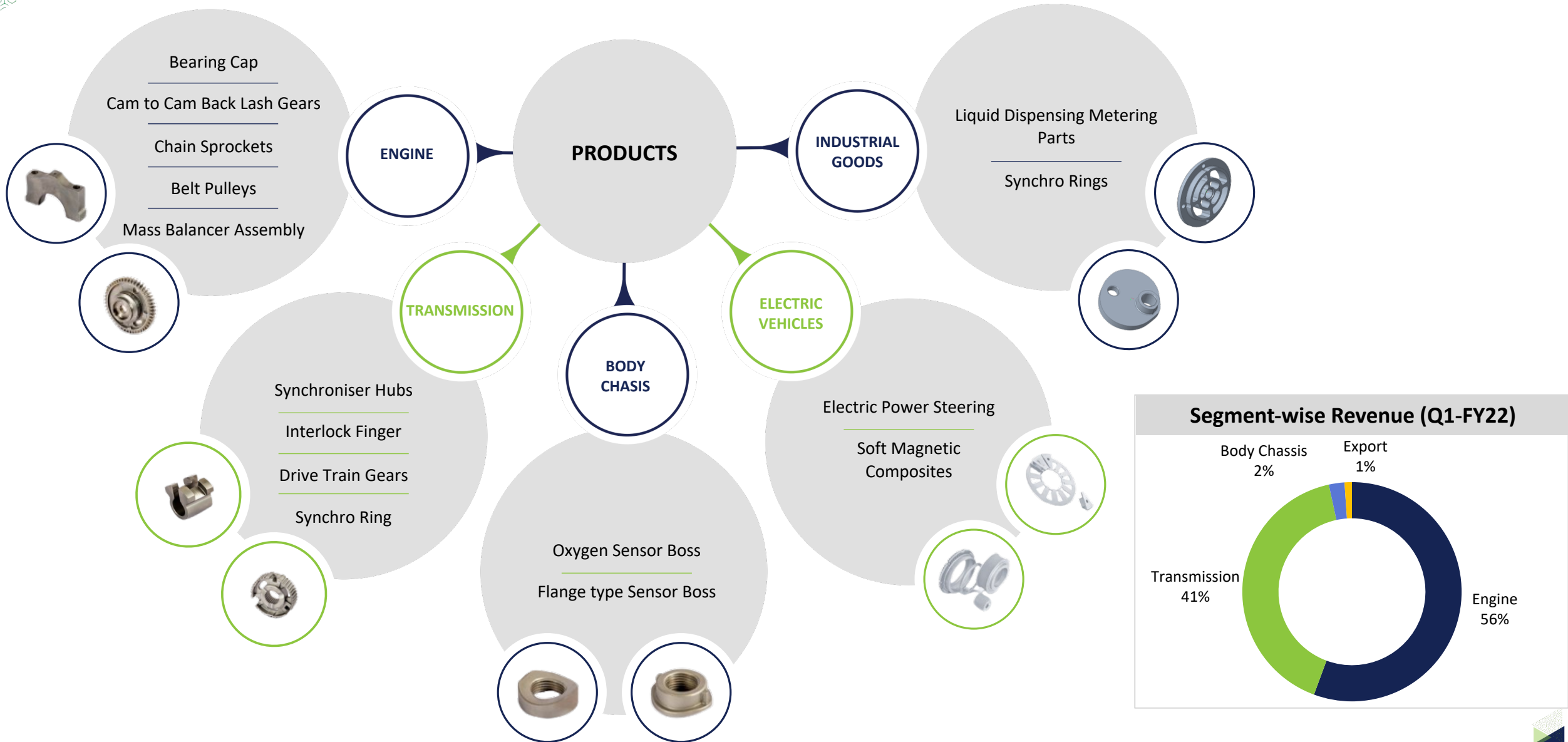

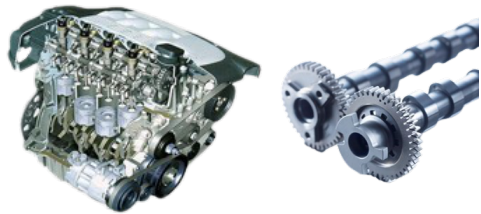

- The engine product portfolio includes engine drive gears, chain sprockets, belt pulleys, and engine shaft bearing caps for engines ranging from 10 to 120 hp.
- These are manufactured using high compressible metal powders and a multi-stage sintering process including specific heat treatments for superior strength and wear resistance.
- These products make the engines more lightweight, energy-efficient, and environment friendly.



BEARING CAP - A bearing cap is the part of the engine block which contains the main bearings of a crankshaft.

APPLICATIONS - 2.0 L Diesel & Gasoline engine, 1.2 L Gasoline engine

FEATURES

- Incorporated with a unique locking feature, perhaps tasked with the most important duty inside of an engine, the cap must be machined properly to allow the correct amount of oil to support the crankshaft and piston rod.
- The proper machining and clearances between the bearing and the crankshaft are accomplished by the fit of the bearing cap.

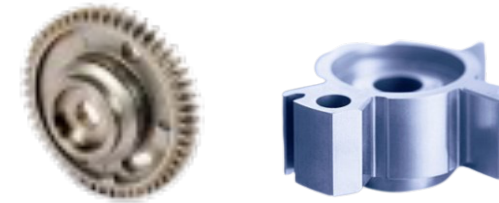

CAM TO CAM BACKLASH GEARS - Designed to reduce the free play/backlash between the camshaft gears and eliminate any knocking noise by ensuring constant contact is being made between two mating gears.

APPLICATIONS – Engine component

FEATURES

- The sub-gear is pushed toward the rotational direction by the spring at all times and the gear reduces the backlash of the gear by meshing with the drive gear, to prevent the noise.
- Backlash is the gap between the gear contact surfaces and due to this NVH is improved.

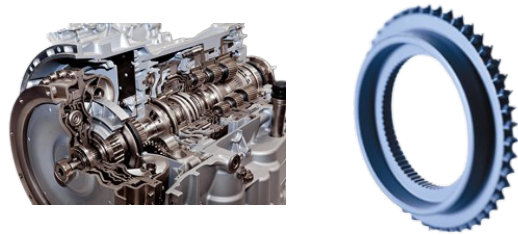

- The product portfolio includes synchro hubs, synchro rings, and drive-train gears.
- Through the technology and engineering process, the company can produce high-precision sintered components for transmissions to replace high strength forged components.
- These components provide superior value for leading automotive customers through better performance and reduction in weight of the drivetrain.



INTERLOCK FINGER - Interlock Finger works in alignment with Shift finger & Block Shift actuator in the gear shifting mechanism.

APPLICATIONS - Gear shifting Mechanism

FEATURES

- Sensing for the reverse gear in automobiles, the sloth and corresponding chamfers are crucial in sensing & support gear shifting mechanism in an automobile.



REVERSE SYNCHRO HUB - Component is used for pre-synchronization, i.e., it generates the load on the synchro ring to perform the synchronization process. The synchronizer hub is rigidly connected by a spline to the rotating shaft (input or output shaft).

APPLICATIONS - 6th Speed Transmission

FEATURES

- Weight reduction holes introduced to reduce the weight of the component, provides raw material saving also act as lubrication Galleries with the improved oil flow through the Synchro pack for better lubrication as well as heat dissipation.
- The component is used for pre-synchronization, i.e., it generates the load on the synchro ring to perform the synchronization process.



- The company produces components of exhaust systems, sensor bosses, and sensor parts like ABS ring for all types of vehicle platforms.



OXYGEN SENSOR BOSS - Interlock Finger works in alignment with Shift finger & Block Shift actuator in the gear shifting mechanism.

APPLICATIONS - Exhaust systems of Automobile

FEATURES

- Bosses are used to mounting oxygen, temperature, Nitrogen oxide, ammonia, and pressure sensors in key locations providing critical performance data for system controllers.



FLANGE TYPE SENSOR BOSS - High-density stainless-steel bosses are manufactured for a variety of applications including the mounting of pressure sensors, temperature sensors, and NOx sensors Configurations include stepped, saddle, and straight with both male and female thread

APPLICATIONS - Exhaust systems of Automobile

FEATURES

- One advantage of the powder metal process is the ability to mold angles and contoured faces without costly secondary machining operations.
- These designs can be achieved by virtually nil material wastages.

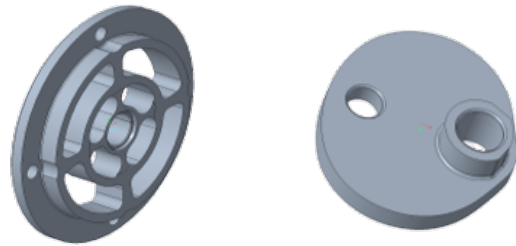

- **LIQUID DISPENSING METERING PARTS** – These are very integral for any unit to determine exact quantity of Fuel dispensed. All types of fuels pass thru the parts with minimal deterring effects on the parts giving a long service life
- **APPLICATIONS:** Stationery & Mobile Fuel Dispensing Units
- **FEATURES:** Dimensional Accuracy, Long Performance,



- **SYNCHRO RINGS** – The purpose of the synchronizer ring is to produce friction torque in order to decelerate/accelerate the **shaft** during a gear shift. The synchronizer ring, together with the friction cone on the gear wheel, form a “conical clutch” which can be engaged and disengaged through sliding
- **APPLICATIONS:** CV and Off road Vehicles
- **FEATURES:** PM synchronizer rings are produced near-net-shape with a minimum of machining stock. Additional operations such as hardening, coating and grinding can be applied as required



- The company is in the development stage for manufacturing of components required in Electric Vehicle.
- In addition to this, it is also equipped to offer soft magnetic composite (SMC) components and assemblies for applications in modern electric motors in addition to, powder metal components for sensors.
- From parts for vehicle electrification to the manufacturing of parts for fully electric vehicles, the company provides solutions for all sectors.



BS6 Sprockets

Uniqueness: Localization along with complex shape.

Total: 7 nos.



Hego Boss SOP for two wheeler application

Uniqueness: Intricate shape.

Total: 4 nos.



Bearing Caps for Diesel and Gasoline engine

Uniqueness: Compaction @ 7.1 density along with unique locking feature.

Total: 4 nos.



Oil Pump Parts

Uniqueness: Localization

Total: 2 nos.



Backlash gears– B

Uniqueness: Rolling technology introduction
Localization

Total: 2 nos.



High speed transmission hubs

Uniqueness: 650 Hv.0.1core hardness via Sinter Hardening route.

Total: 4 nos.

Manufacturing Metrics

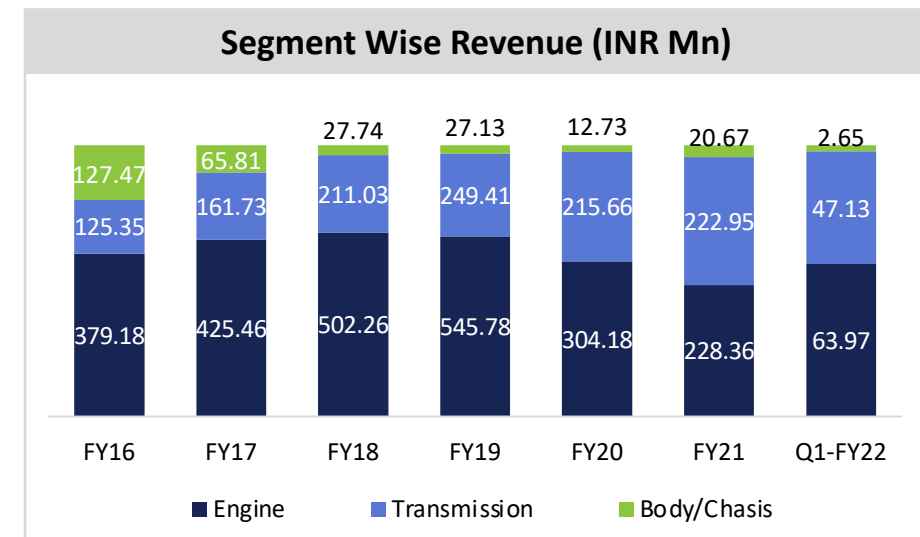
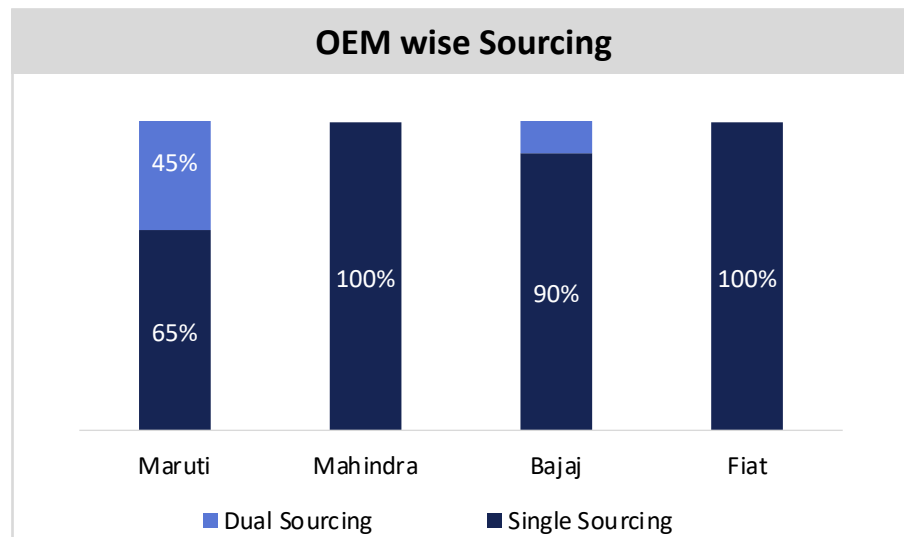
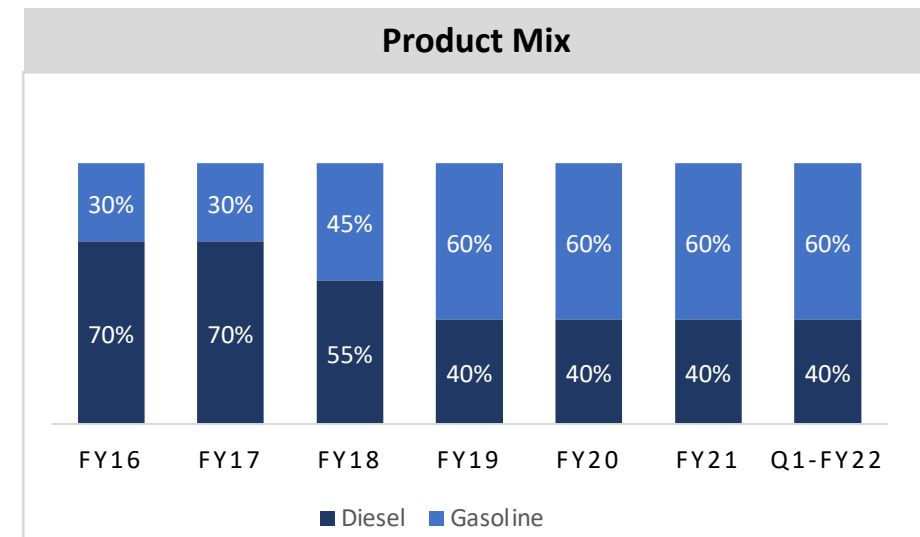
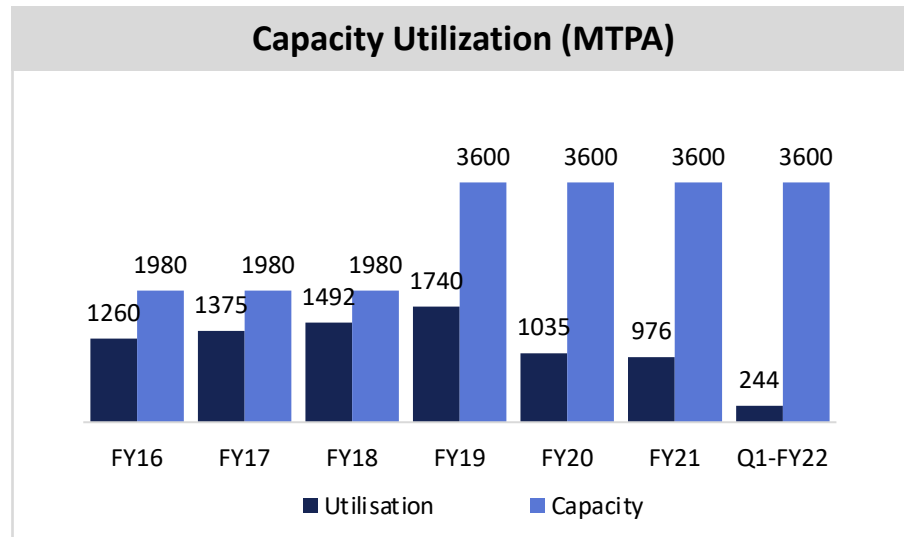



Industry Overview & Future Growth Opportunities



- India became the fourth largest auto market in 2019 displacing Germany with about 3.99 million units sold in the passenger and commercial vehicles categories. India is expected to displace Japan as the third-largest auto market by 2021.
- The two-wheeler segment dominates the market in terms of volume owing to a growing middle class and a young population. Moreover, the growing interest of the companies in exploring the rural markets further aided the growth of the sector.
- India is also a prominent auto exporter and has strong export growth expectations for the near future. Also, several initiatives by the Government of India and major automobile players in the Indian market are expected to make India a leader in the two-wheeler and four-wheeler market in the world by 2021.
- Two wheelers and passenger vehicles dominate the domestic Indian auto market. Passenger car sales are dominated by small and mid-sized cars. Two-wheelers and passenger cars accounted for 80.8% and 12.9% market share, respectively, accounting for a combined sale of over 20.1 million vehicles in FY20.
- As per the Society of Indian Automobile Manufactures (SIAM) the total production of Passenger Vehicles, Commercial Vehicles, Three-wheelers, Two-wheelers and Quadricycle in FY-21 was 22,652,108 units, as against 26,353,293 units in FY-20, witnessing a de-growth of 14.04%.
- A total of 2,711,457 units of Total Passenger Vehicles were sold in FY-21, as compared to 2,773,519 units in FY-20, resulting in a de-growth of 2.24%
- In the FY20-21, there was a de-growth in sales of all segments compared to the previous years. (-) 13.19% for Two-Wheelers with sales of 151.19 Lakhs units; (-) 20.77% for Commercial Vehicles with sales 5.69 Lakhs units and (-) 66.06% for Three-Wheelers with sales of 2.16 Lakhs units
- Also in the report by SIAM, total 404,400 units of Passenger Vehicles were exported in FY-21, as compared to 662,118 units in FY-20 and 50,334 units of Commercial Vehicles were exported in FY-21, as compared to 60,379 units in FY-20, resulting in a de-growth of 38.92% and 16.64%, respectively.
- A total of 392,941 units of Three-wheelers were exported in FY-21, as compared to 501,651 units in FY-20 and 3,277,724 units of Two-wheelers were exported in FY-21, as compared to 3,519,405 units in FY-20, resulting in a de-growth of 21.67% and 6.87%, respectively
- EV sales, excluding E-rickshaws, in India witnessed a growth of 20% and reached 1.56 lakh units in FY20 driven by two-wheelers.
- The automobile industry is supported by various factors such as the availability of skilled labour at low cost, robust R&D centers, and low-cost steel production. The industry also provides great opportunities for investment and direct and indirect employment to skilled and unskilled labour.
- Indian automotive industry (including component manufacturing) is expected to reach USD 251.4-282.8 billion by 2026.

Number of automobiles produced (In Mn)

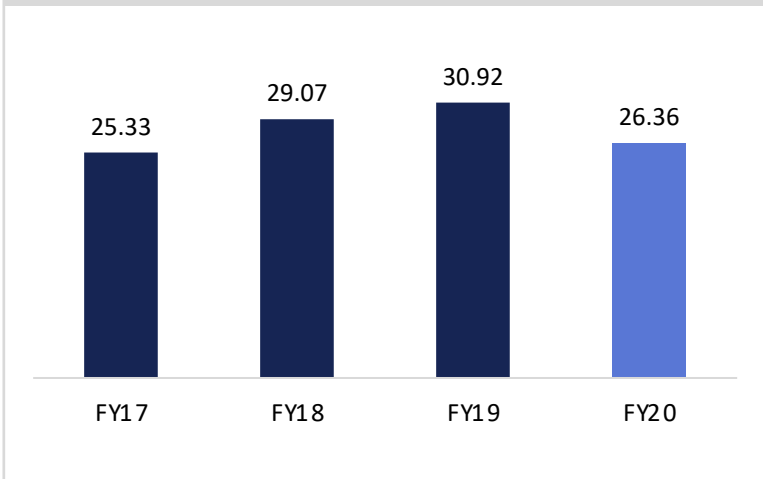

Share of each segment in total production volume (FY20)

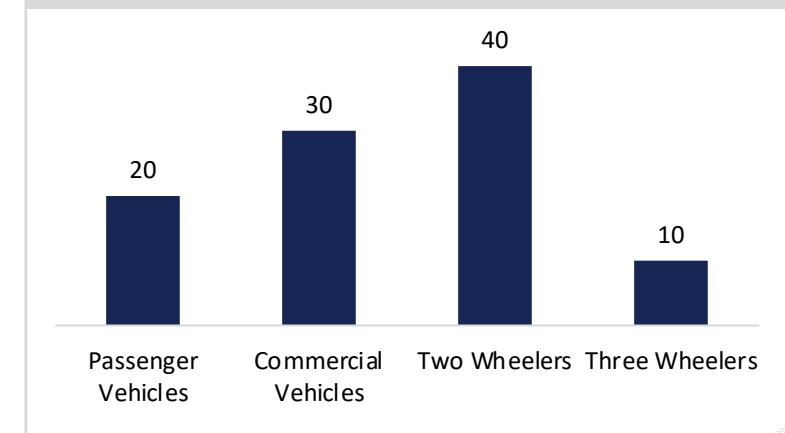

- The Indian auto-components industry has experienced healthy growth over the last few years. The auto-components industry reached USD 49.3 billion in FY20.
- Auto-components industry accounts for 2.3% of India's Gross Domestic Product (GDP) and employs as many as 1.5 million people directly and indirectly. A stable government framework, increased purchasing power, large domestic market, and an ever-increasing development in infrastructure have made India a favourable destination for investment.
- The industry can be broadly classified into organized and unorganized sectors. The organized sector caters to original equipment manufacturers (OEMs) and consists of high-value precision instruments while the unorganized sector comprises low-valued products and caters mostly to the aftermarket category.
- As per Automobile Component Manufacturers Association (ACMA), automobile components export from India is expected to reach USD 80 billion by 2026. The Indian auto components industry is expected to reach USD 200 billion in revenue by 2026.
- Indian Automobile industry is expected to achieve a turnover of USD 300 billion by 2026 and will grow at a CAGR of 15% from its current revenue of USD 74 billion.
- As per the Union Budget 2019-20, the Government moved the GST council to lower the GST rate on EVs from 12% to 5%. Also, to make EVs affordable to consumers, the Government will provide an additional income tax deduction of INR 1.5 lakh (USD 2,115) on the interest paid on loans taken to purchase EVs.
- In November 2020, the Union Cabinet approved the PLI scheme in automobile and auto components with an approved financial outlay over a five years of INR 57,042 crore (USD 8.1 billion).
- Government has come out with Automotive Mission Plan (AMP) 2016-26 which will help the automotive industry to grow and will benefit the Indian economy in the following ways: -
 - Contribution of the auto industry in the country's GDP will rise to over 12%.
 - Around 65 million incremental numbers of direct and indirect jobs will be created.
 - End of life policy will be implemented for old vehicles
- The rapidly globalizing world is opening newer opportunities for the transportation industry, especially while it makes a shift towards electric, electronic and hybrid cars, which are deemed a more efficient, safe, and reliable modes of transportation. Over the next decade, this will lead to newer verticals and opportunities for auto-component manufacturers, who would need to adapt to change via systematic R&D.
- As per ACMA forecasts, automobile component export from India is expected to reach USD 80 billion by 2026.
- The Indian auto-components industry is set to become the third-largest in the world by 2025. Indian auto-component makers are well-positioned to benefit from the globalization of the sector as export potential could be increased by up to USD 30 billion by 2021E.

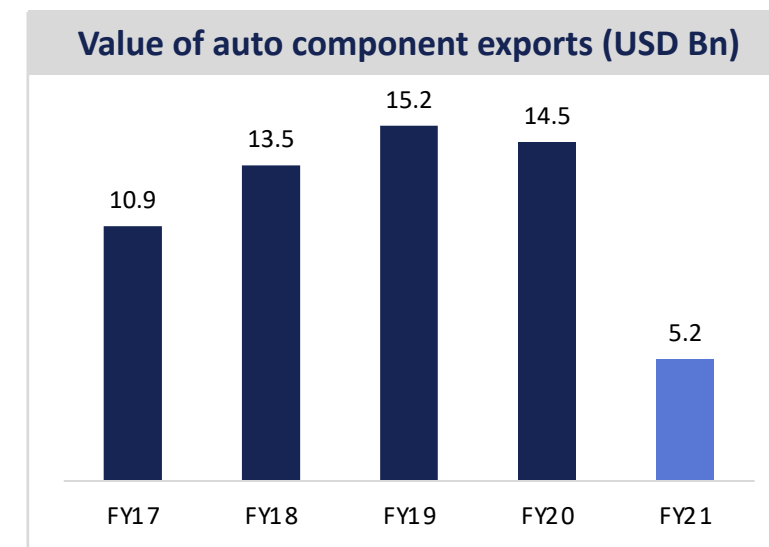
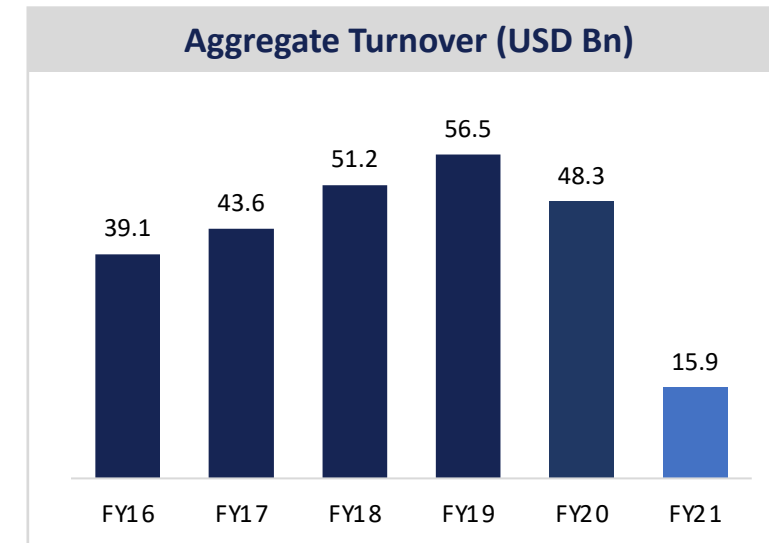

Process

Sintering

- Powder metal is compacted into net shape using die tooling
- Compacted components are then sintered into furnaces at high temperatures below the melting point in a phase-wise manner
- Up to 90% dense symmetric components can be produced

Other Sintering Processes

Isostatic Sintering

- Powder metal is compacted into net shape using isostatic pressure on die walls
- Compacted components are then sintered into furnaces at high temperatures below the melting point in a phase-wise manner
- Up to 90% dense symmetric and long components can be produced

Metal Injection Molding

- Powder metal is injected inside the injection molds using an extruder, similar to plastic injection moulding.
- Moulded components are then sintered in high-temperature vacuum furnaces
- Up to 99% dense and complex shape components can be produced

Additive Manufacturing

- Powder metal is spray printed layer upon layer using 3D modeling software enabled 3D printer
- Simultaneously, through laser or other concentrated sources, it is heated and sintered in real-time.
- Any shape and components can be produced

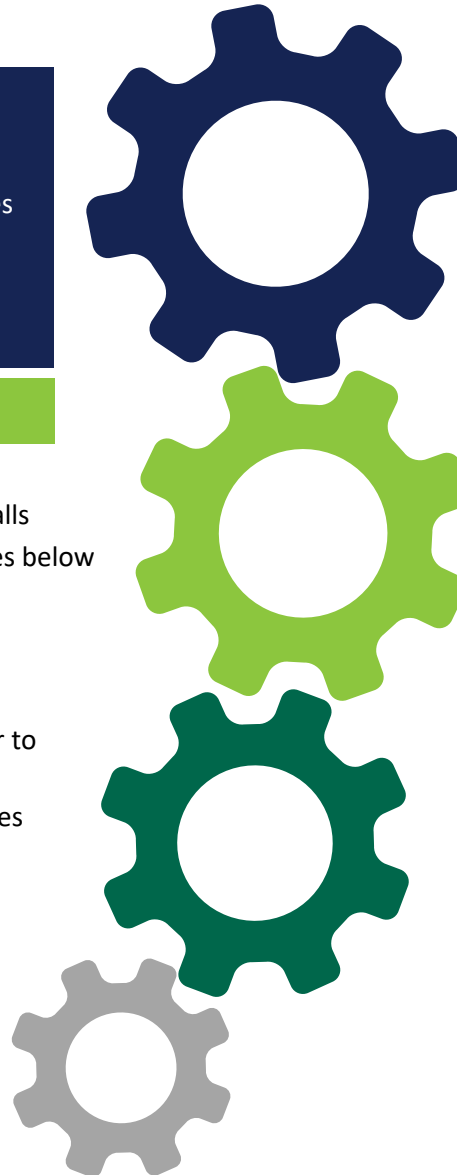

Application

Automotive

- Engine: Gears, Sprockets, Rotors, Pulleys, Spacers
- Transmissions: Synchro Hubs, Synchro Rings, Shift tower components
- Auxiliary: Alternator and Turbocharger components, Water pump rotors, Fuel injectors
- Body/Chassis: Sensor ring, Sensor boss

Sintering in other Industries

Aerospace / Defence

- Valve bodies
- Fuel injectors
- Alternator and electric motor components
- Firearm components

Medical Equipment

- Surgical instruments
- Surgical implants
- Electric components of medical equipment

Consumer Goods

- Electric components like motors and inverters
- Connecting rods and pistons of compressors
- Soft magnetic cores
- Valve bodies

Future Business Strategy & Growth Drivers



Key Business Strategies:

- **Enhancing our customer base:** Continue to enhance OEM network and work closely with OEM customers to develop new products for their vehicles and marketing and branding and further intend to widen the sales network to access more customers through in-house marketing team by way of inter-alia presenting to them the technologies the company have. The company is exploring opportunities in the global market
- **Forward Integration:** With the increasing focus of Make in India in the fields of defense and aerospace, the company intend to expand the manufacturing process from conventional sintering to metal injection molding (MIM) and into the defense and aerospace industry with MIM products
- **Expanding our product base:** Considering the substantial operational costs, the company anticipates that the OEMs will look for the outsourcing of component assemblies. Currently, the company is only a component supplier to its customer. The company however intends to become an assembly supplier for the OEMs wherein the component assembly would be done in-house and capitalize on this opportunity considering the technology backup from the Miba Sinter Austria GmbH
- **Improving functional efficiencies:** The company intends to improve efficiencies to achieve cost reductions and have a competitive edge over its peers and this can be achieved through continuous process improvement, customer service, and technology development. They also strive to improve the quality of the products manufactured and impart technical training at regular intervals to their employees to enhance their skills

Growth Drivers:

- **Exploring more opportunities with BS-VI norms:** With the mandate for compliance with BS-VI norms in India, the company have enhanced demand for BS-VI compliant products and market the same to Tier 1 customers
- **Shift in customer perception:** There will be an increase in demand for personal cars post covid as people will avoid using public transports
- **Vehicle scrappage policy:** It will give a big boost to the Indian Automobile industry turnover as it will increase the demand for a new vehicle
- **Sintered components usage in different countries:** In developed countries like the USA, Europe, sintered components per vehicle are around 12-16 kg per vehicle. In India, we have the opportunity to increase sinter component in an automobile from 4 kgs to 10 kgs per vehicle
- **China +1 strategy:** This could prove beneficial for Indian exporters, as global buyers will not be dependent on a single country for sourcing products
- **Atmanirbhar Bharat:** All these initiatives are likely to help Indian auto component manufacturers resume business and fortify the supply chain. Furthermore, this will also help companies ramp up their businesses and reduce automaker's reliance on other countries for components
- **Café 2 Norms:** The forging doesn't perform well in terms of reducing Noise, Voice, and Harshness so they have to move to sinter. So like that, there is lot of components which is required in the petrol engine, that have to be made using sintered technology

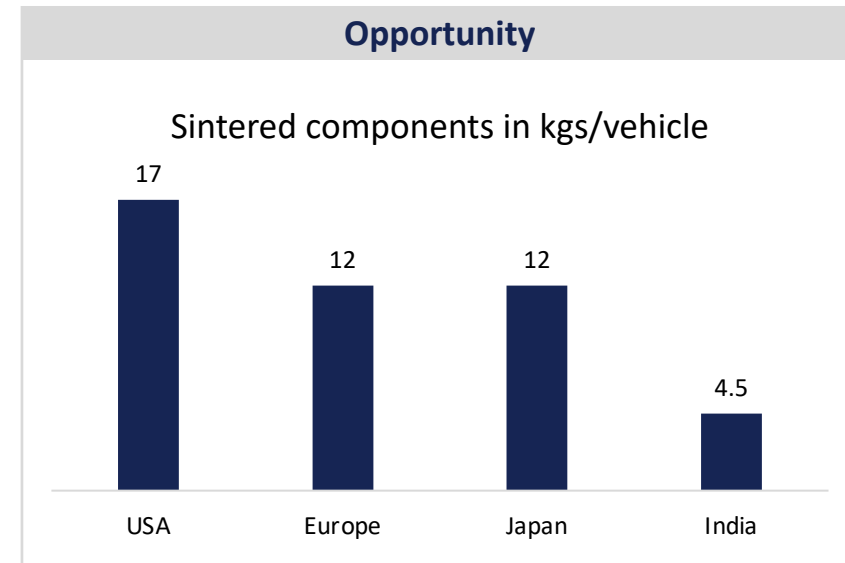
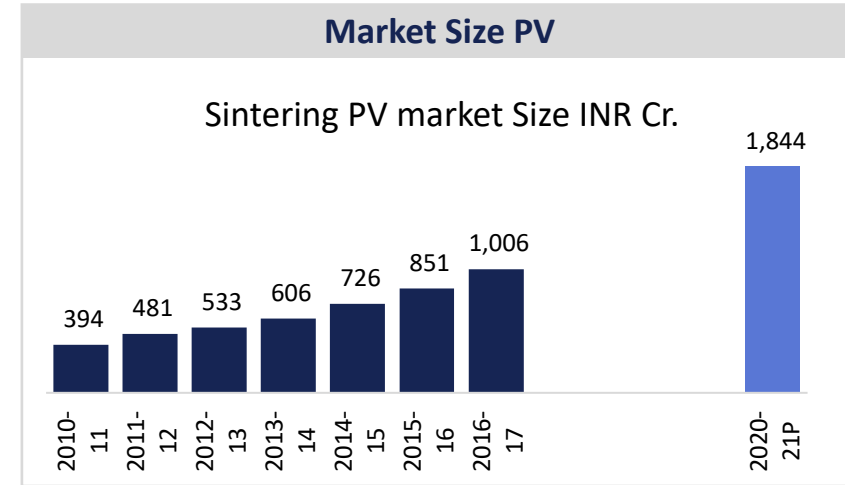

The Road to Fuel Efficiency & CO₂ Compliance – Regulatory Landscape



Markets starting to align below a nominal 100g/km NEDC equivalent creating significant cost challenges for OEM's

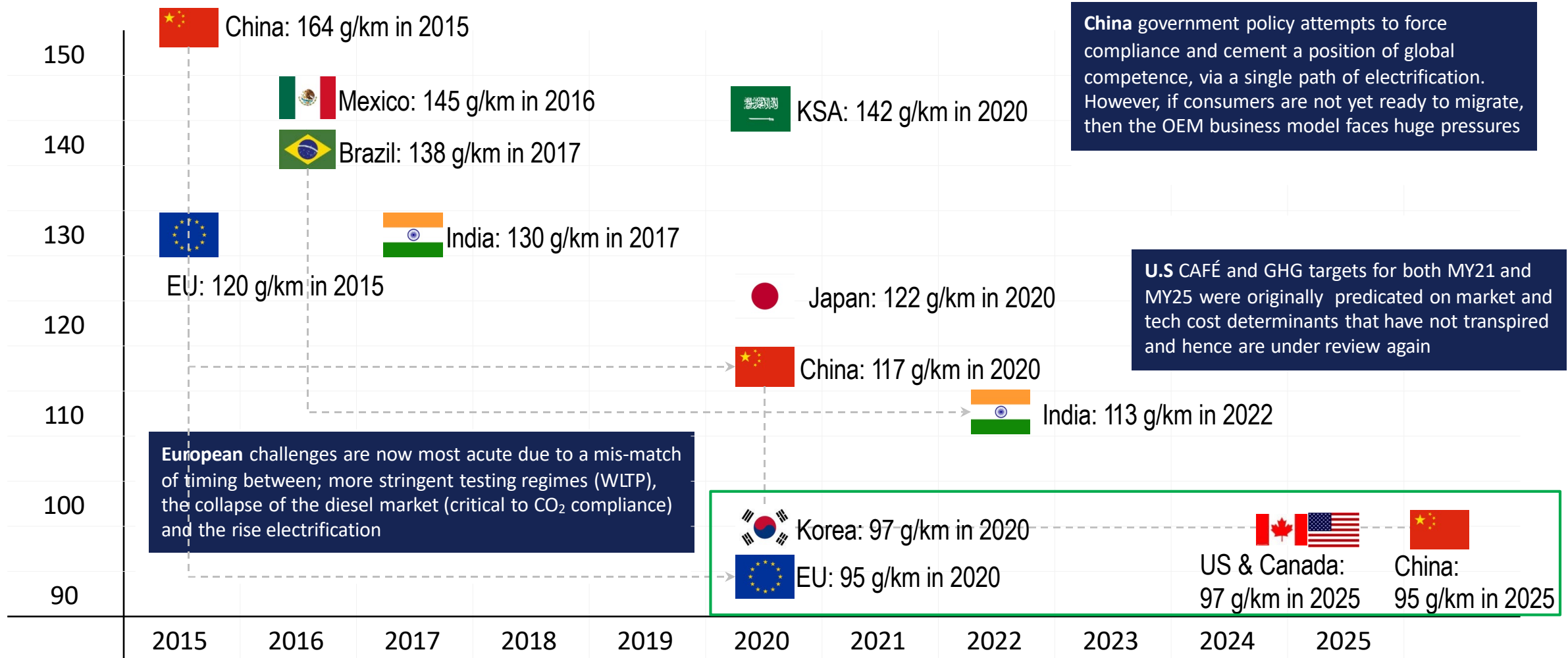

China government policy attempts to force compliance and cement a position of global competence, via a single path of electrification. However, if consumers are not yet ready to migrate, then the OEM business model faces huge pressures

U.S CAFÉ and GHG targets for both MY21 and MY25 were originally predicated on market and tech cost determinants that have not transpired and hence are under review again

European challenges are now most acute due to a mis-match of timing between; more stringent testing regimes (WLTP), the collapse of the diesel market (critical to CO₂ compliance) and the rise electrification

Korea: 97 g/km in 2020	EU: 95 g/km in 2020	US & Canada: 97 g/km in 2025
		China: 95 g/km in 2025

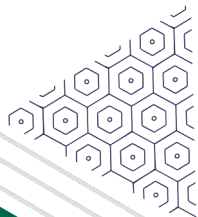

Financial Overview



Income statement



Particulars (INR Mn)	FY19	FY20	FY21	Q1-FY22
Revenue from Operations	827	535	472	115
Expenses	647	464	438	110
EBITDA	180	71	34	5
EBITDA Margin (%)	21.77%	13.27%	7.20%	4.35%
Other Income	5	1	5	2
Finance cost	39	38	39	5
Depreciation and amortisation expenses	70	68	62	16
Profit before tax	76	(34)	(62)	(14)
Tax expense	21	(5)	(15)	(3)
PAT	55	(29)	(47)	(11)
PAT Margin (%)	6.65%	NA	NA	NA
Other Comprehensive income	-	-	-	-
Total Comprehensive income	55	(29)	(47)	(11)
Diluted EPS (INR)	2.27	(1.18)	(1.18)	(0.41)

Balance sheet



Equity and Liabilities (INR Mn)	FY20	FY21
Share Capital	242	256
Reserves and Surplus	620	782
Total Equity	862	1,038
Non Current Liabilities		
Long-term borrowings	119	72
Deferred tax liabilities (Net)	38	22
Long term provisions	35	22
Other long term liabilities		
Sub Total Non Current Liabilities	192	116
Current Liabilities		
Short-term borrowings	121	79
Trade payables	129	103
Other financial liabilities	42	64
Other current liabilities	128	119
Short-term provisions	0	0
Sub Total Current Liabilities	420	365
TOTAL EQUITY AND LIABILITIES	1,474	1,519

Assets (INR Mn)	FY20	FY21
Non-current assets		
Fixed assets		
Property, Plant & Equipment	798	740
Other Intangible assets	125	130
Capital work-in-progress	1	1
Intangible assets under development	39	40
Long term loans & advances	5	5
Other non current assets	65	50
Sub Total Non Current Assets	1,033	966
Current assets		
Inventories	158	192
Trade receivables	187	212
Cash and cash equivalents	8	82
Short-term loans and advances	2	2
Other current assets	86	65
Sub Total Current Assets	441	553
TOTAL ASSTES	1,474	1,519

Key Financial Highlights



Revenue (INR Mn)

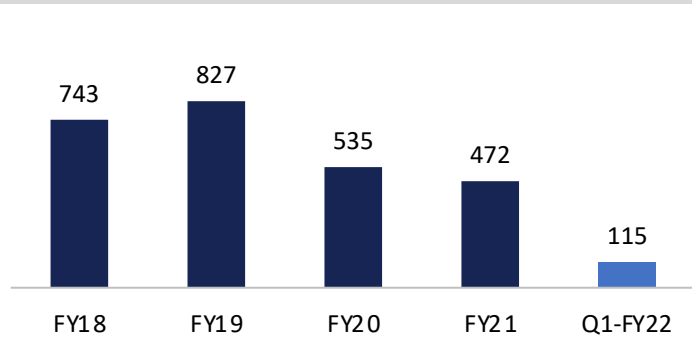

EBITDA (INR Mn) & EBITDA Margin (%)

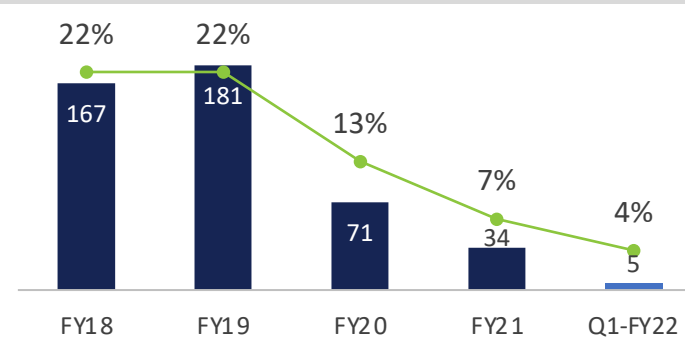

PAT (INR Mn) & PAT Margin (%)

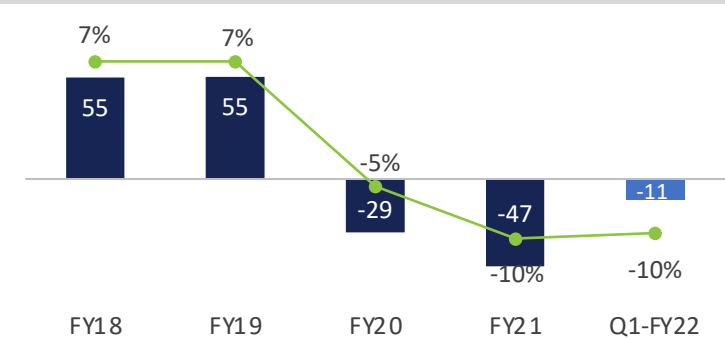

Cash Conversion Cycle (Days)

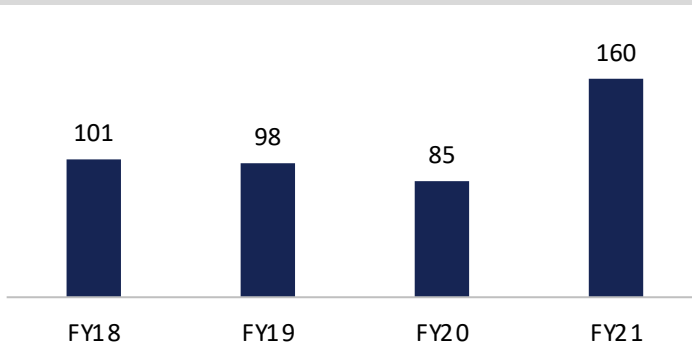

RoCE (%) and RoE (%)

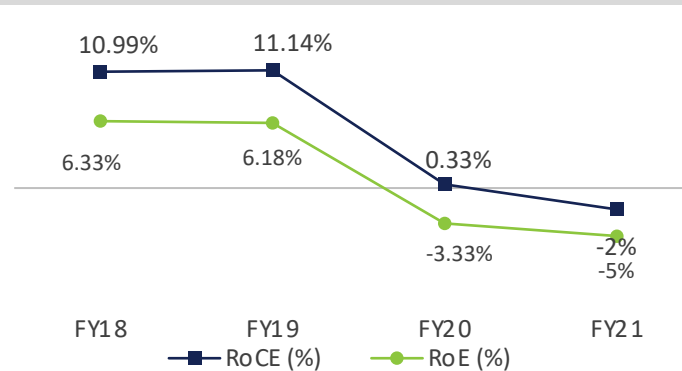

Net Debt/Equity (x)

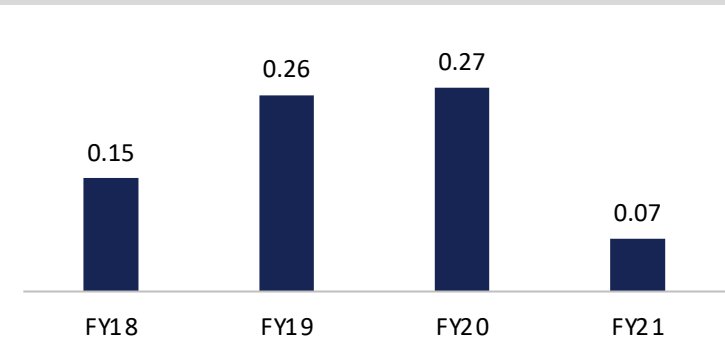

Stock Return (As on 30th June 2021)

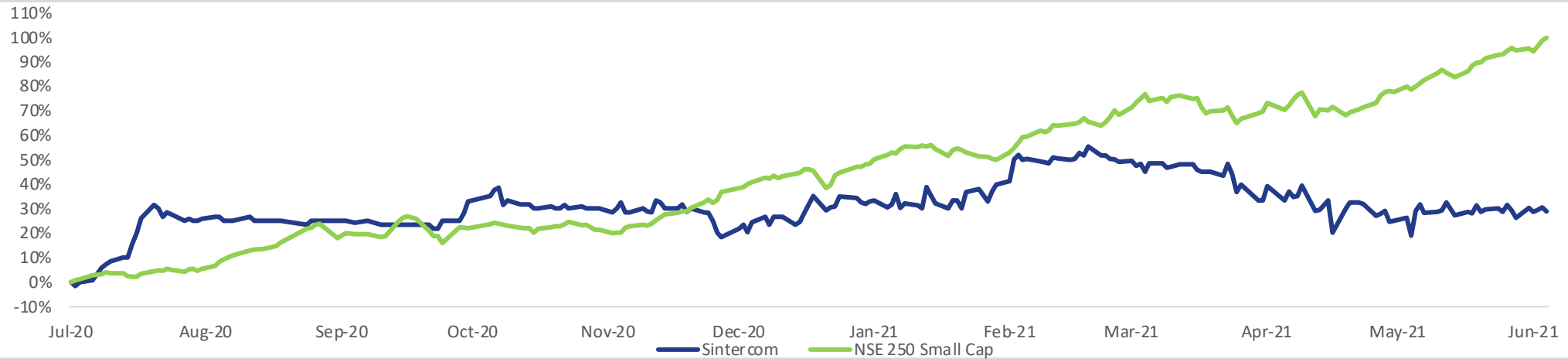

Price Data (As on 30th June 2021)

Face value (INR)	10.00
Market Price (INR)	79.25
52 Week H/L (INR)	99.45/58.00
Market Cap (INR Mn)	2,025.06
Equity Shares Outstanding (Mn)	25.55
1 Year Avg. trading volume ('000)	11.44

Shareholding Structure (As on 30th June 2021)

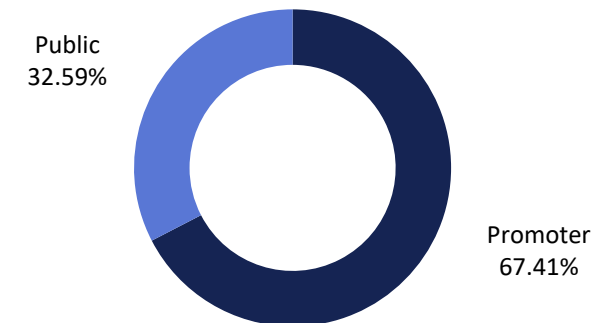

Sintercom India Disclaimer:

No representation or warranty, express or implied, is made as to, and no reliance should be placed on, the fairness, accuracy, completeness or correctness of the information or opinions contained in this presentation. Such information and opinions are in all events not current after the date of this presentation. Certain statements made in this presentation may not be based on historical information or facts and may be "forward looking statements" based on the currently held beliefs and assumptions of the management of Sintercom India Ltd., which are expressed in good faith and in their opinion reasonable, including those relating to the Company's general business plans and strategy, its future financial condition and growth prospects and future developments in its industry and its competitive and regulatory environment.

Forward-looking statements involve known and unknown risks, uncertainties and other factors, which may cause the actual results, financial condition, performance or achievements of the Company or industry results to differ materially from the results, financial condition, performance or achievements expressed or implied by such forward-looking statements, including future changes or developments in the Company's business, its competitive environment and political, economic, legal and social conditions. Further, past performance is not necessarily indicative of future results. Given these risks, uncertainties and other factors, viewers of this presentation are cautioned not to place undue reliance on these forward-looking statements. The Company disclaims any obligation to update these forward-looking statements to reflect future events or developments.

This presentation is for general information purposes only, without regard to any specific objectives, financial situations or informational needs of any particular person. This presentation does not constitute an offer or invitation to purchase or subscribe for any securities in any jurisdiction, including the United States. No part of it should form the basis of or be relied upon in connection with any investment decision or any contract or commitment to purchase or subscribe for any securities. None of our securities may be offered or sold in the United States, without registration under the U.S. Securities Act of 1933, as amended, or pursuant to an exemption from registration there from.

This presentation is confidential and may not be copied or disseminated, in whole or in part, and in any manner.

Valorem Advisors Disclaimer:

Valorem Advisors is an Independent Investor Relations Management Service company. This Presentation has been prepared by Valorem Advisors based on information and data which the Company considers reliable, but Valorem Advisors and the Company makes no representation or warranty, express or implied, whatsoever, and no reliance shall be placed on, the truth, accuracy, completeness, fairness and reasonableness of the contents of this Presentation. This Presentation may not be all inclusive and may not contain all of the information that you may consider material. Any liability in respect of the contents of, or any omission from, this Presentation is expressly excluded. Valorem Advisors also hereby certifies that the directors or employees of Valorem Advisors do not own any stock in personal or company capacity of the Company under review.

For further details, please feel free to contact our Investor Relations Representatives:



Mr. Anuj Sonpal
Valorem Advisors
Tel: +91-22-49039500
Email: sintercom@valoremadvisors.com

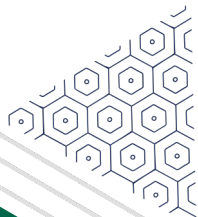

Thank You!

